



Optimal productivity

- Continuous 360° turntable rotation
- Full proportional controls and simultaneous boom functions
- Narrow turning radius (3.9 m)
- Zero tailswing

Outstanding rough terrain driving features

- 4 wheel steer and 4 wheel drive mean greater manoeuvrability
- Industry leading 13.5 m outreach
- Hydraulic differential lock
- 42 cm ground clearance

Robust, reliable and easy to maintain

Haulotte 
GROUP

More than lifting





HA20 PX

ROUGH TERRAIN ARTICULATING BOOMS

TECHNICAL DATA

HA20 PX

Working height	20.65 m
Platform height	18.65 m
Horizontal outreach	13.5 m
Up and over clearance	6.8 m
Lift capacity	230 kg
F x G Platform size	1.8 x 0.8 m
A Length	8.93 m
B Width	2.38 m
C Height - stowed	2.67 m
H Transport length	6.8 m
Transport height	3.1 m
Vertical jib rotation	140° (+70/-70)
Platform rotation	180° (+90/-90)
Turntable rotation	360°
Tailswing	0 m
D Wheelbase	2.8 m
E Ground clearance	42 cm
Tilt	5°
Drive speed	0.5 - 4.5 km/h
Gradeability	40 %
Turning radius - outside	3.9 m
Tires - foam-filled	385/65-22.5
Power source	31.2 kW - 42.4 hp
Weight	11 710 kg

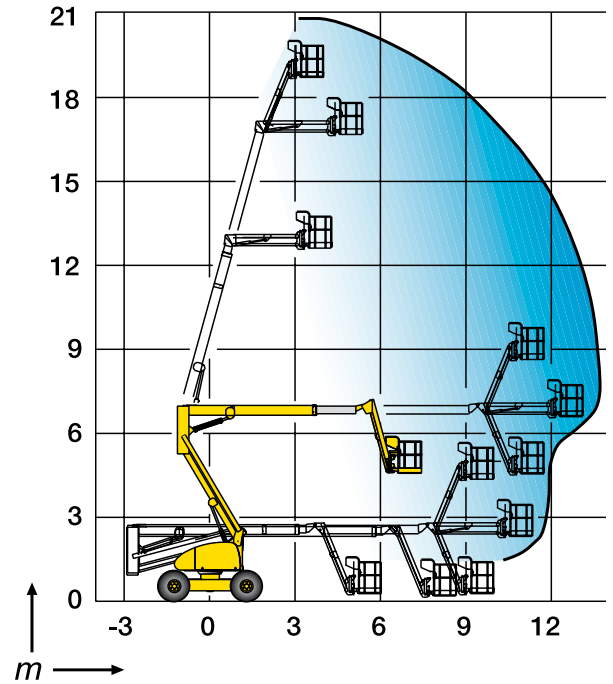

STANDARD EQUIPMENT

- 4 wheel drive and steer
- Continuous 360° turntable
- Safe to use in winds up to 45km/h
- 150 l fuel tank; 1.50 m filling height
- 5° tilt alarm
- 12 V battery / electrical control system
- Auxiliary power in platform
- Brake release
- Hourmeter
- Mechanical turret slewing hook
- Towing hooks / lifting eyes

OPTIONS AND ACCESSORIES

- Power to platform
- 3.3 kW on-board generator (belt driven)
- Large platform 2.44 x 0.8m
- Travel alarm
- Rotating beacon
- Working light
- Catalytic exhaust
- Biodegradable hydraulic oil
- Cold weather package
- Warm environment kit
- Non marking tires
- Flashing light
- 60 km/h wind package (maximum capacity 250 kg ; machine weight 12,260 kg)

